

PARKING BRAKE RELAY CONFIGURATION

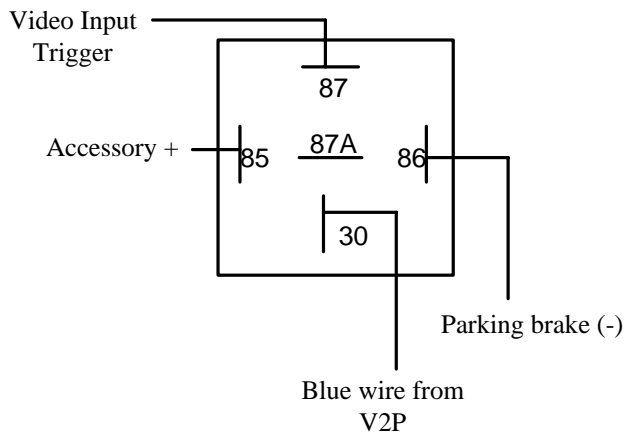

This NAV-TV device is for back-up camera use, therefore it does not have a safety interlock wire. In some states, having video visible by the driver is illegal. Other states allow video up front only while the vehicle is stationary. Please refer to the following diagram to add the emergency brake interlock.