

A complex geometric wireframe pattern of thin grey lines forming various polygons, serving as a background for the entire page.

# AR 20

---

OPERATING MANUAL



**AUTHOR**  
ALARM

version 802.1

## TABLE OF CONTENTS

General information .....	4
Advantages of AR20 .....	4
How it works? .....	5
Relay installation .....	5
Specifications .....	7
Contents of the set .....	7

## General information

Universal electromechanical relay AR20 can be used in normally closed and normally open circuit in any electric circuit of a car that can be blocked that leads to engine locking and preventing the car from moving.

AR20 relay can be used together with wide variety of anti-theft devices for additional protection and control:

- anti-theft system IGLA
- anti-theft device RAPTOR
- anti-theft immobilizer KVANT
- hood lock control module CONTOUR

and other devices designed by AUTHOR and other companies.

## Advantages of AR20

- Dust and moisture protection
- Embedded snubber for back induction current protection
- Protection from polarity reversal (reverse connection of the wires)
- Peak load of 25 A
- Working temperatures from 40 to 85°C

## How it works?

The relay is controlled via signal applied to the blue wire (12V, max. 250 mA). The yellow wire shall be connected to the circuit of the different potential or shall be grounded. When there is a signal on the green wire (NO) the positive power potential «+» coming from the purple wire (NC).

When working with black power cable (COM) it is necessary to have constant positive potential «+».

## Relay installation

For example let's take the connection of AR20 relay and IGLA anti-theft system for the additional protection contour.

Locking of an additional contour is made through the normally-closed scheme. It is used in the event of emergency (when the digital locking is available) so it can be used for any circuit break that blocks the engine even if it leads to temporary errors (for instance, in the bent shaft or injector power supply sensor circuit). Locking takes place by sending the negative potential to the blue wire while the ignition is on or the engine is running (can be tracked on the analogue «ignition» input, yellow wire).

1. **Black.** Ground/earth.
  2. **White.** CAN-L.
  3. **Brown.** CAN-H.
  4. **Red.** DC+.
  5. **Grey.** For initial settings on «+».
  6. **Yellow.** Ignition.
  7. **Blue.** Negative output to a locking relay (250mA max).
  8. **Orange.** IGLA system state output «-» (250mA max).  
When the authorization is successfully completed the minus potential remains while the engine is working. The output is needed for joint use with other devices or for normally-opened locking circuit.
- A. Purple.** Normally closed contact.  
**B. Green.** Normally opened contact.  
**C. Black.** General.

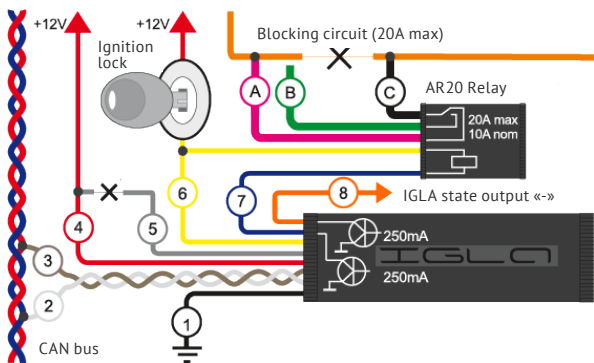

## Specifications

Operating voltage .....	7-15 V
Max constant voltage .....	14 V
Contacts pattern .....	SPDT
Operating current (for 14 V) .....	20 A
Working temperatures range .....	-40 ... +85 °C
Dust and waterproof protection .....	IP67

## Contents of the set

Electromechanical relay AR20	1 pcs.
Operating manual	1 pcs.
Packing	1 pcs.



Made in Russia

Manufacturer: LLC «DMA Group»

C-RU.AЛ14.B.10097

The developer and the manufacturer retain the right to make technical updates not specified in this operating manual. To learn more visit our web-site:

<http://author-alarm.com>



## WARRANTY CERTIFICATE

Warranty is 12 months from the date of the purchase. During this period technical support and maintenance are guaranteed for free.

The warranty does not apply to the items with:

- mechanical damage, burnt and char pieces, components, conductive tracks etc.;
- traces of an independent repair;
- damage caused by natural hazards, fire, social factors;
- violation of the tamper-evident seal, damage or absence of a factory/trade label.

Only items in complete set and with the original packing are taken for warranty repair.

Absence of packing is regarded as noncompliance with transportation rules. The warranty does not apply to the damage incurred to another equipment operating together with this device.

Item (model) \_\_\_\_\_

Sale date \_\_\_\_/\_\_\_\_/\_\_\_\_\_

The contents of delivery \_\_\_\_, functioning \_\_\_\_, absence of mechanic damage \_\_\_\_ are checked.

I am acquainted and agree with the condition of warranty service:

Buyer \_\_\_\_\_

Seller \_\_\_\_\_ seal











Supported Cars List App.

